

Full Retention Class 2 FR-NS-20-HHH Volume 7,500 lit

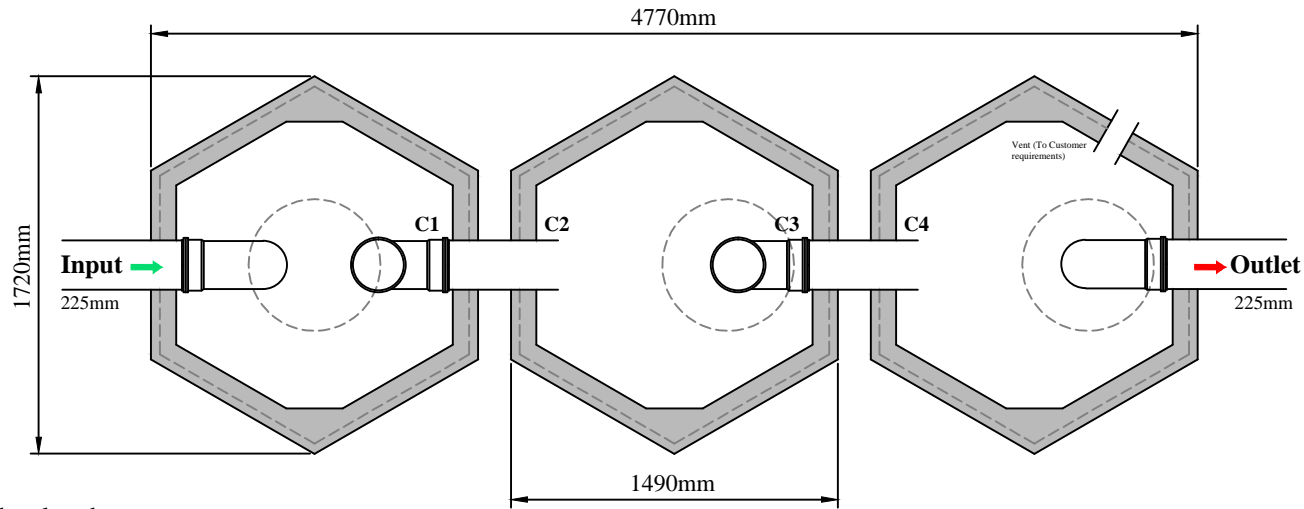

All the tanks must be placed on a perfectly level and firm suitable base.
Typical layout, variations as required per customer.

An anti-syphon vent is required for long run outflows

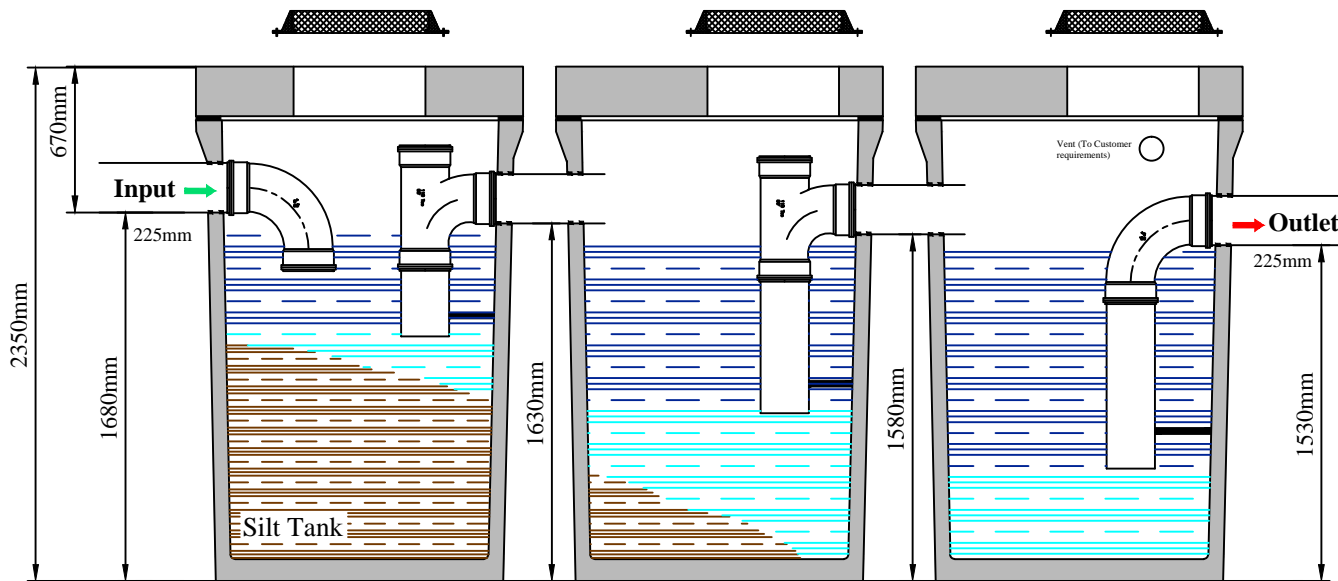

Notes:

This drawing is ©. All rights reserved.
Note: Observe all safety regulations in regard to excavation and lifting requirements. Never leave opening uncovered or unattended at any time.
Note: Specify any specific requirements prior to ordering. All civil works by customer.
Note: Do not scale from this drawing. Only for illustration purposes.

Tank Type: 3H Full Retention Interceptor
Tank Size: 4770mm x 1720mm
Height: 2350mm
Volume: 7500 liters
Weight: 1500kg (Each, Ex. Lid)
(Tank Dim: ± 20mm. Weight: ± 30Kg.)

20 l/s flow
1,110m sq. coverage
1,500 lit. emergency oil retention
2,300 lit. silt capacity



Clara Road, Tullamore, Co. Offaly, Ireland
Tel: 057 9326000 info@molloyprecast.com
Fax: 057 9326060 www.molloyprecast.com

Title: FR-NS-20-CL2-3H
Full Retention Interceptor
Date: June 2012
Drg. No.: FR-NS-20-CL2-3H-00
Drawn By: SC