

## Pumping Station - H Tank Dual Pumps (2,500 L)

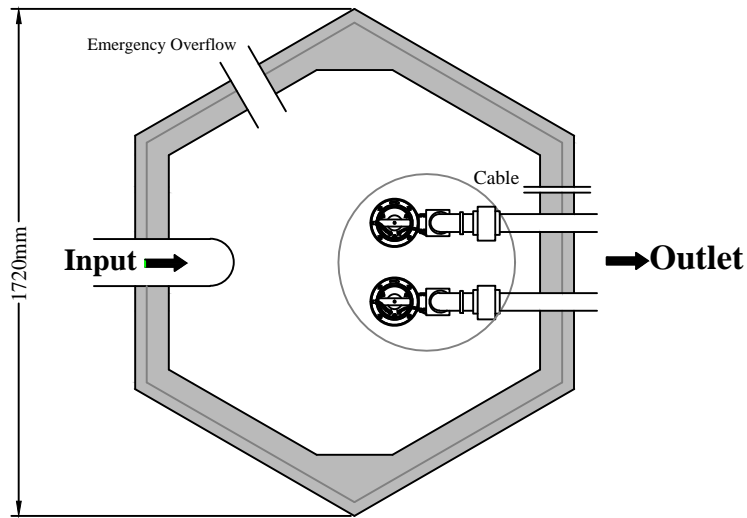

Adjustments can be made to pumping station according to customer requirements.

Variety of pumps available. Contact Molloy Precast for suitable pump.

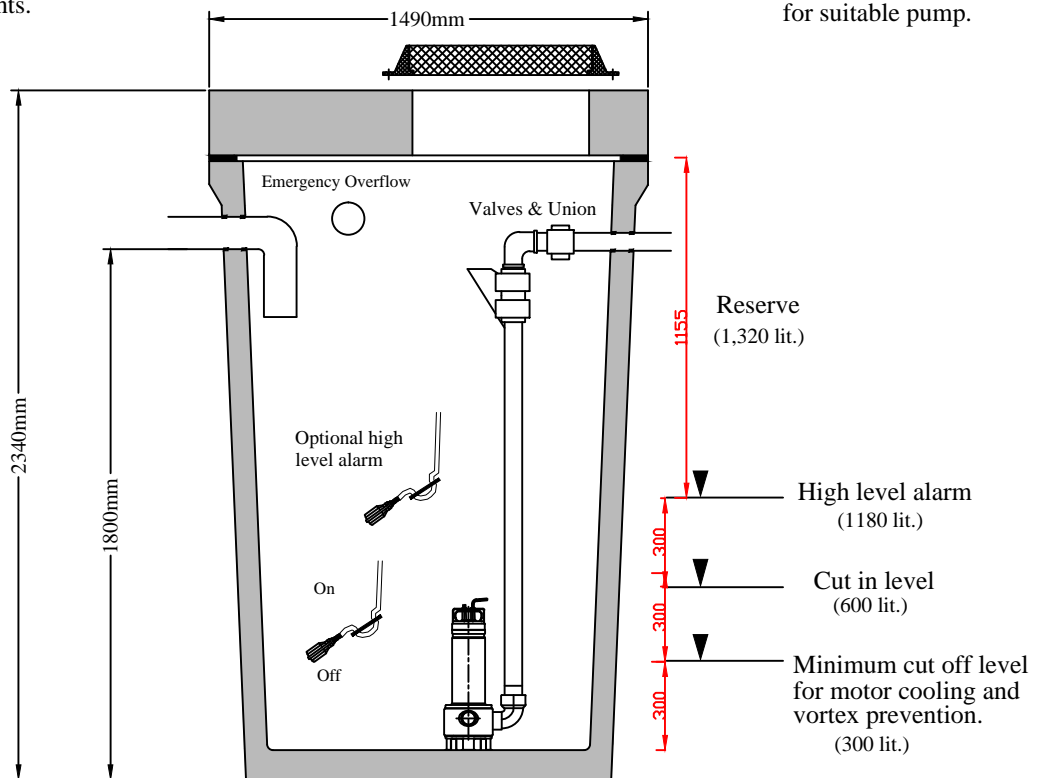

A good firm, rock free, level base is required.



Clara Road, Tullamore, Co. Offaly, Ireland  
 Tel: 057 9326000 info@molloyprecast.com  
 Fax: 057 9326060 www.molloyprecast.com

**Note:** Observe all safety regulations in regard to excavation and lifting requirements. Never leave opening uncovered or unattended at any time.  
**Note:** Specify any specific requirements prior to ordering. All civil works by customer.  
**Note:** Do not scale from this drawing. Only for illustration purposes.

<b>Tank Type:</b> H	<b>Title:</b> Pumping Station - H Dual Pumps
<b>Tank Size:</b> 1720mm x 1490mm	<b>Pump Capacity:</b> Contact Molloy Precast
<b>Height:</b> 2340mm	<b>Date:</b> June 2012
<b>Volume:</b> 2500 liters	<b>Dr. No.:</b> PS-H(2)-00
<b>Weight:</b> 1500 kg	<b>Drawn By:</b> MFC
<b>(Tank Dim: ± 20mm. Weight: ± 30Kg.)</b>	This drawing is ©. All rights reserved.