

110mm Inlet pipe
adequate ventilation to
be provided in the sewer
network

Outlet connections
available to suit
rising main

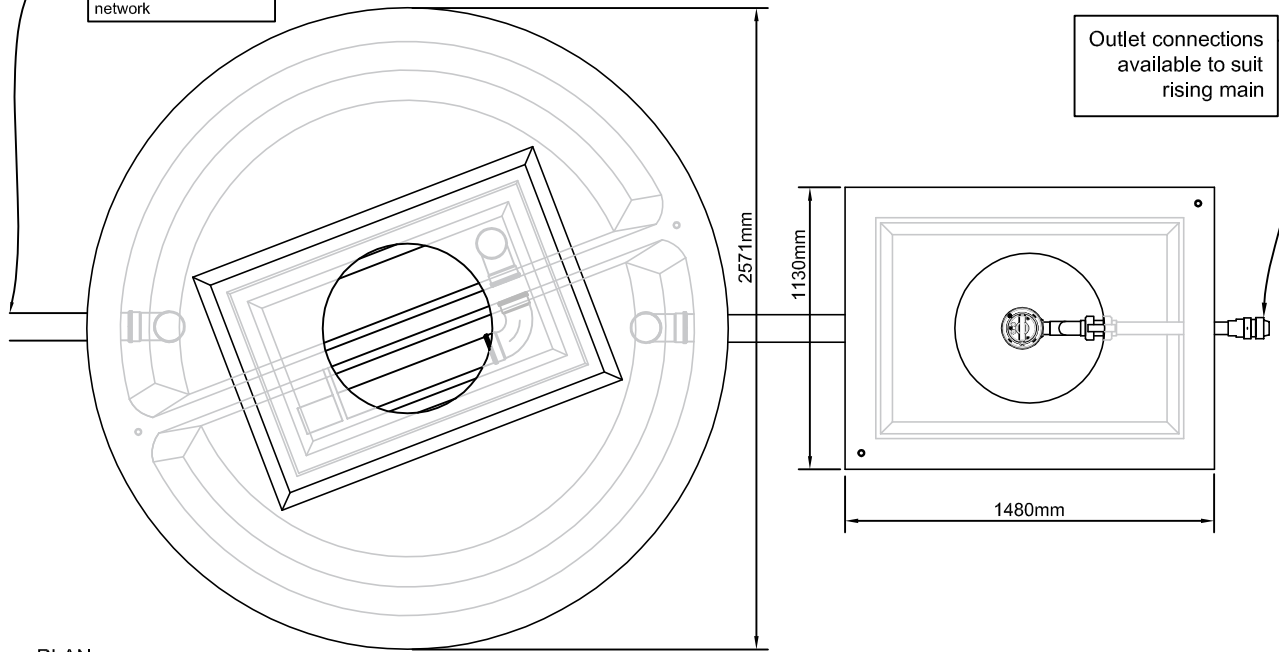

PLAN

Concrete manhole cover with
lift points. Note: Optional steel
manhole covers available.

Optional: Highwater
float switch with
indoor alarm panel

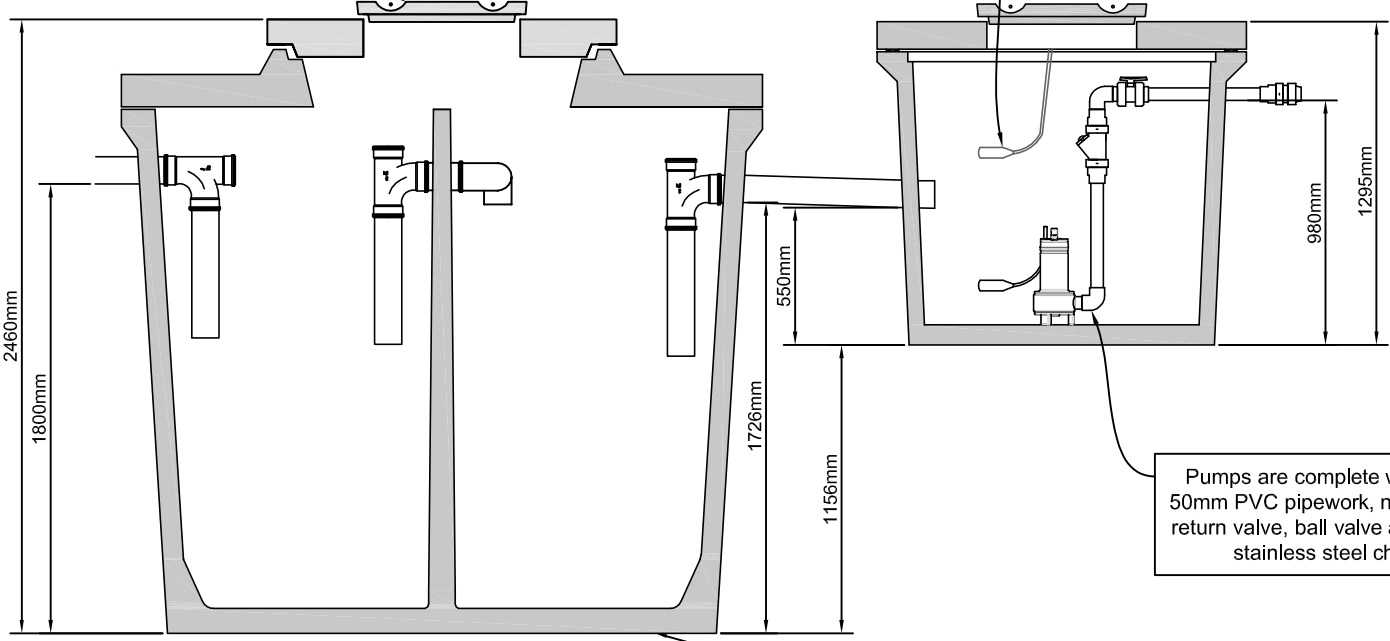

Pumps are complete with
50mm PVC pipework, non-
return valve, ball valve and
stainless steel chain

Ensure a good firm, rock free
level base is provided. refer to
your site engineer

SECTION

MOLLOY
ENVIRONMENTAL SYSTEMS
Clara Rd., Tullamore, Co. Offaly
T: 057 9326000 E: Info@mollyprecast.com
F: 057 9326060 W: www.mollyprecast.com

Tank lifting limitations:
Max chain angle < 60°

< 60° > 60°

✓ ✗

Damage caused by
incorrect lifting is the
responsibility of others

- Notes:**
- Observe all safety regulations in regard to excavation and lifting requirements. Never leave opening uncovered or unattended at any time
 - Specify any specific requirements prior to ordering. All civil works by customer
 - Do not scale from this drawing. Only for illustration purposes

Title: Septic S+ Tank NS-4 with pump sump
Certification: EN 12566-1, hydraulic efficiency 99.84%
Tank Type: S+ Tank ,J Tank
Weight: S Tank 6,830kg ,J Tank 1,600kg
Dwg. no.: Septic_S+ tank_PS_140619
Date: 17/07/2019
Drawn by: SF